

Supernode

USER PROGRAMMABLE, 48 WAY I/O, DATALOGGER & TASK MANAGER



Automotive applications
Type approved: e marked

The user programmable SUPERNODE consolidates the four functions of inputs, outputs, datalogging and system control into one single unit. This makes it suitable for applications where a centralized vehicle control is preferred.

The SUPERNODE has all you need to implement intelligent control features on your vehicle, improving its safety, increasing operator ease of use, and bringing down the cost of build and cost of ownership.

The system is fully field proven with thousands of installations worldwide. It is suitable for ambulances, police, fire, cash in transit, outside broadcast, libraries, recovery, trailers, traffic management in fact any vehicle where relay control is insufficient, datalogging necessary or wiring burdensome.

The product is fully supported in both hardware and software by Antares.

FEATURES

- 12V or 24V installation
- IP65 packaging
- 180A total output
- 18 solid state 13A outputs
- 6 solid state 2A outputs
- 24 digital inputs
- "bulb failure" detection
- Digital circuit breakers
- Circuit power indicator LEDs
- PWM/Flash/Delay control
- Integral datalogger
- Windows programmable
- SAE J1939 CAN interface
- CANBUS extendable

Programmable

The functionality of the Supernode is created using an intuitive windows © based program. Once created, the functionality is uploaded at the press of a button. This means that the nodes for different vehicles can be kept in stock for support and easily configured for the vehicle. It also means that the vehicle can be easily upgraded during its life—ideal for fast moving areas such as the emergency services.

Once trained on the system you will be able to build in a variety of features from

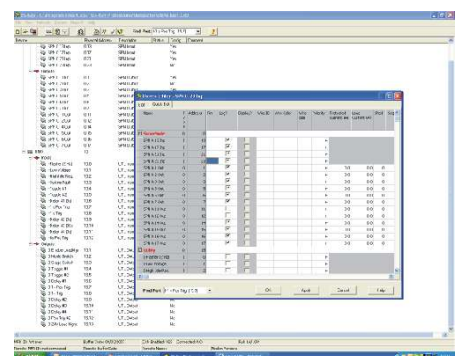

FM 37786
ISO 9001:2000

Antares (Europe) Limited
Chiltern Hill
Chalfont St Peter
Gerrards Cross
Buckinghamshire
SL9 9UQ UK

www.antares.co.uk
email: info@antares.co.uk
tel: +44 (0)1753 890888
fax: +44 (0)1753 891260

ANTARES
engineering with answers

Supernode

USER PROGRAMMABLE, 48 WAY I/O, DATALOGGER & TASK MANAGER

simple switching and flashing lights, through to safety interlocks. Ongoing support is provided by our engineers

Datalogging

The system logs any selected activity on the Supernode, fully timestamped, with a reporting facility. This will allow the fleet operator to know when the vehicle is driven, when it is recharged, when the emergency lights are on .. The list is endless.

Wiring and Looming

This is simplicity itself. All wires are routed directly from the Supernode to the loads and switches and terminated. The power is supplied by two fused feeds... that's it!

The SUPERNODE is a simple but highly featured module which brings unparalleled functionality to your vehicle ... you can now say goodbye to relays and experience the full benefits of a modern solid state programmable electrical system.

Extras

Extra supernodes—Up to three supernodes can be used together providing all the I/O you could possibly need.

Extra Switches -You can wire your existing switches directly to the inputs or alternatively add one of our prepackaged switch panels which come in 2,4,6 and 8 switch arrays.

Extra Displays—The system can be equipped with a four line LCD display to display warnings, switch status and other driver information.

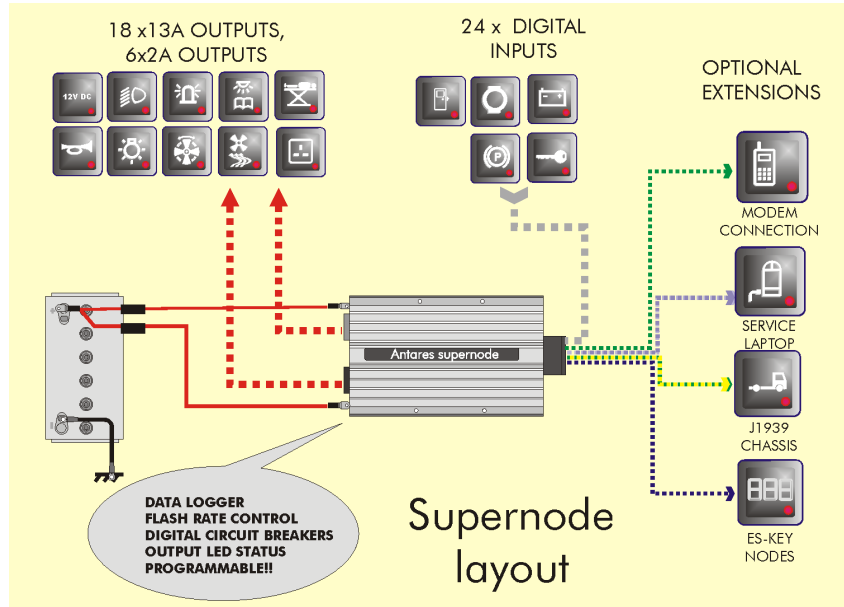

TECHNICAL DETAILS	
Voltage range	+9VDC....+32VDC
Power consumption	500mA@13.8VDC 350mA@32VDC
Power output	13A positive polarity 2A ground polarity
Temperature range	40°C ... +85°C
Environmental range	IP65
CAN specification	SAE J1939 proprietary, 250kbits/second
LEDs	25 green LEDs for power circuit indication
Protection	Internal thermal fuse (2.5A on RS232 input) Reverse voltage protection on RS232 CANBUS protected to 24V ESD voltage, transient voltage, and load dump to SAE J1113 Outputs protected for S/C and overload
Dimensions	222mm (L) 202mm(W) x 63mm (H)
Weight	2.0kg
Mating connector Power	Deutsch DT06-12SBBLACK & GREY Wire gauge 16-18AWG
Mating connector Digital	Deutsche DRC26-40SA Black Wire gauge 20-24AWG
Software license	Es_Key Pro software operating under Windows© Microsoft corporation